

POMPE PER DRENAGGIO DRAINAGE PUMPS



SAND 100





SAND 150-200



SAND 300

 Pompe sommergibili particolarmente indicate per acque sabbiose, scavi edilizi, impianti di verniciatura, scantinati. Robusta costruzione. Coperchio, cassa statore, corpo di mandata e supporto in ghisa. Girante in ghisa di tipo bicanale aperto. Albero in acciaio inox temperato e rettificato. Motore a bagno d'olio. Tenuta meccanica in carburo di silicio e anello di tenuta in viton sui modelli "SAND 50" e "SAND 100". **Doppia tenuta meccanica in carburo di silicio in camera d'olio** sui modelli "SAND 150" - "SAND 200" - "SAND 300". Cavo di alimentazione da 10 m. in neoprene H07RNF. Tensione monofase 230 V / 50 Hz con condensatore e protezione termica incorporati; tensione trifase 400 V / 50 Hz con protezione a cura dell'utente. Protezione IP 68. Isolamento classe F. Temperatura massima del liquido da pompare 50 °C; pH 6 – 11; massima densità 1100 kg/m³.

 Submersible pumps suitable to remove sandy water: drainage of foundation trenches, subways, varnishing plants, etc. Heavy duty construction. Pump housing in cast iron. Open-type double channel impeller in cast iron. Oil bathed motor. Shaft in stainless steel. Mechanical seal in silicon carbide and lip seal ring in viton on the models "SAND 50" and "SAND 100". **Double mechanical seal in silicon carbide in oil chamber** on the models "SAND 150" - "SAND 200" - "SAND 300". 10 m. supply cable H07RNF. Single-phase voltage 230 V / 50 Hz with built-in capacitor and motor protector; the three-phase voltage 400 V / 50 Hz pump must be protected by a fused remote isolator switch. Protection class IP 68. Insulation class F. Max. temperature of pumped liquid 50 °C; pH 6 – 11; max. density 1100 kg/m³.

 Pompes submersibles indiquées pour le drainage des eaux contenant du sable: fouilles de fondations, vide-caves, passages souterrains, cabines de peinture, etc. Construction robuste. Couvercle, corps de pompe, corps de refoulement et support en fonte. Roue en fonte de type bicanal ouvert. Arbre en acier inox. Moteur à bain d'huile. Garniture mécanique en carbure de silicium et bague d'étanchéité à lèvres sur les modèles "SAND 50" et "SAND 100". **Double garniture mécanique en carbure de silicium en chambre d'huile** sur les modèles "SAND 150" - "SAND 200" - "SAND 300". Câble électrique H07RNF de 10 m. Bobinage monophasé 230 V / 50 avec condensateur et protection thermique incorporés; bobinage triphasé 400 V / 50 avec protection par l'utilisateur. Protection IP 68. Isolation classe F. Température max. du liquide pompé 50 °C.; pH 6 – 11; densité max. 1100 kg/m³.

 Tauchpumpen für Regen- und Sandwasser. Hergestellt aus hochwertigen und widerstandsfähigen Materialien. Pumpengehäuse und Zweikanallaufwerk aus Grauguß. Antriebswelle aus rostfreiem Stahl. Ölgefüllter Tauchmotor. Gleitringdichtung aus Siliziumkarbid und Öldichtungsring aus Viton bei Modellen "SAND 50" und "SAND 100". **Ölgekühlte Doppel-Gleitringdichtung aus Siliziumkarbid** bei Pumpen "SAND 150" - "SAND 200" - "SAND 300". 10 M. Kabel H07RNF. Einphasenspannung 230 V / 50 Hz mit Kondensator und thermischen Motorschutz; Dreiphasenspannung 400 V / 50 Hz: Motorvollschutz nach Benutzersorge. Schutzart IP 68. Isol. Klasse F. Max. Temperatur der Flüssigkeit 50 °C; PH-Wert 6 – 11; max. Dichte 1100 kg/m³.

Modello Model Modèle Modell	Potenza Power Puissance Pferdestärke		Tensione Voltage Bobinage Spannung	A	Prevalenza - Head - Hauteur - Förderhöhe (m)															
	hp	kW			Portata - Capacity - Débit - Fördermenge (l/min)															
					2	4	6	8	10	12	14	16	18	20						
SAND 50	0,5	0,37	230/50/1	3,0	200	166	117	50												
SAND 100	1	0,75	230/50/1	4,8	315	270	220	170	100	40										
			400/50/3	2,4																
SAND 150	1,5	1,1	230/50/1	8,5	400	350	300	250	200	125	50									
			400/50/3	3,5																
SAND 200	2	1,5	230/50/1	9,7	510	470	420	360	295	225	150	50								
			400/50/3	4,6																
SAND 300	3	2,2	400/50/3	5,4	670	625	570	510	450	380	310	230	140	50						

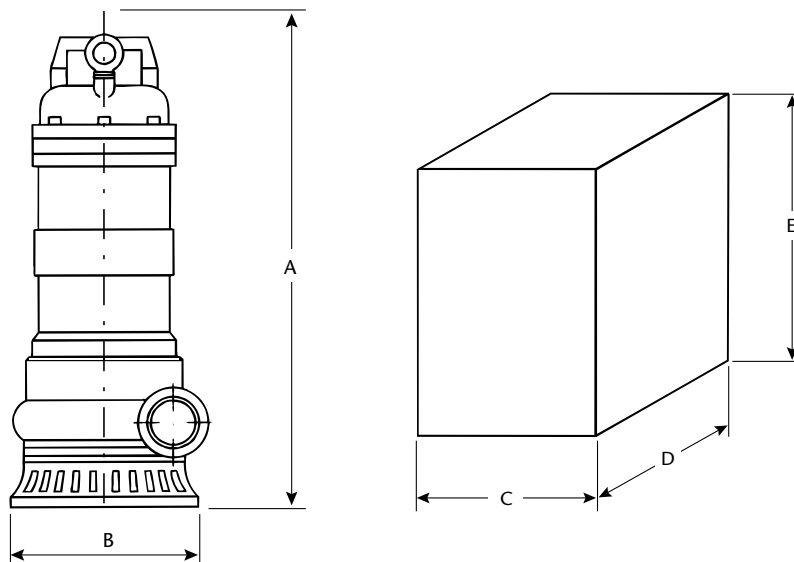
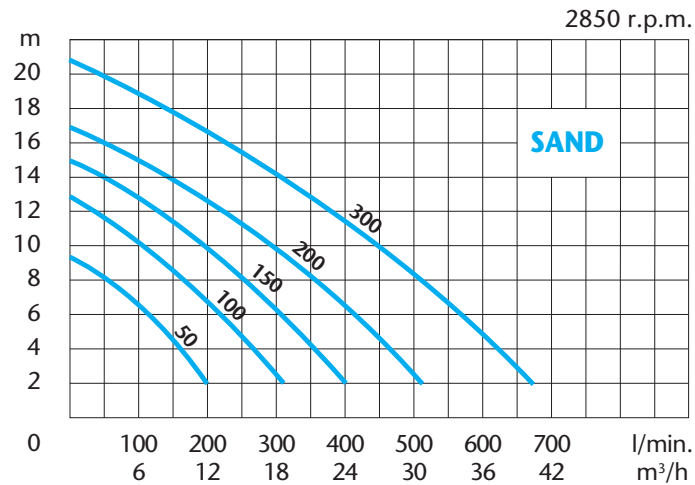

Modello Model Modèle Modell	Mandata Discharge Refoulement Druck-Seite	Dimensioni - Dimensions - Masstabelle					Peso Weight Poids Gewicht
		mm					
		A	B	C	D	E	
SAND 50	1"1/4	308	140	190	180	350	10
SAND 100	1"1/2	425	165	230	200	490	21
SAND 150	2"	490	200	275	255	550	34
SAND 200	2"	514	200	275	255	550	35
SAND 300	3"-DN 80	525	210	275	255	550	40